

GENERAL DESCRIPTION

The PJ20030 series is a high-accuracy, low-noise, high-speed, high-PSRR, and low-dropout CMOS linear regulator with high ripple rejection. The devices offer a new level of cost-effective performance in cellular phones, laptop and notebook computers, and other portable devices.

The PJ20030 has the fold-back maximum output current that depends on the output voltage. So the current limit functions both as a short-circuit protection and as an output current limiter.

The device is available in DFN1x1-4, SOT23-5, and DFN2x2-6 packages.

FEATURES

- ◆ Operating input voltage range : 1.6 V to 5.5 V
- ◆ Output voltage range : 0.8 V to 3.3 V
- ◆ Output current : 300 mA
- ◆ Ultra-low quiescent current : 25 μ A typ.
- ◆ Dropout voltage : 170 mV at IOUT = 300 mA
- ◆ PSRR: 75 dB at 1 kHz, IOUT = 20 mA
- ◆ Output voltage tolerance : \pm 1%
- ◆ Stable with ceramic capacitors 1 μ F
- ◆ Thermal-overload protection
- ◆ Short-circuit protection
- ◆ Quick output discharge :
 - PJ20030A: With output discharge
 - PJ20030B: Without output discharge
- ◆ Available in small DFN1x1-4, SOT23-5, and DFN2x2-6 packages
- ◆ These devices are Pb-Free, halogen Free/BFR free, and are RoHS compliant

SIMPLIFIED SCHEMATIC

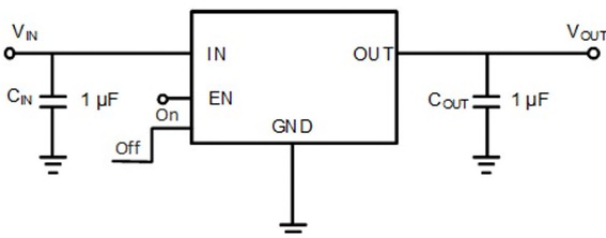

APPLICATIONS

- ◆ MP3/MP4 players
- ◆ Cellphones, radiophones, digital cameras
- ◆ Bluetooth, wireless handsets
- ◆ Others portable electronics devices

ORDERING INFORMATION

| ORDER NUMBER | Marking ID | Package | Description |
|-------------------|------------|----------|-------------------------------------|
| PJ20030A-xxS5_R1 | AABDNN | SOT23-5 | Halogen Free in T&R, 3000 pcs/Reel |
| PJ20030A-xxQZ1_R1 | A W | DFN1x1-4 | Halogen Free in T&R, 10000 pcs/Reel |
| PJ20030A-xxQW_R1 | AABC | DFN2x2-6 | Halogen Free in T&R, 3000 pcs/Reel |
| PJ20030B-xxS5_R1 | AABDNN | SOT23-5 | Halogen Free in T&R, 3000 pcs/Reel |
| PJ20030B-xxQZ1_R1 | A W | DFN1x1-4 | Halogen Free in T&R, 10000 pcs/Reel |
| PJ20030B-xxQW_R1 | AABC | DFN2x2-6 | Halogen Free in T&R, 3000 pcs/Reel |

| Output Voltage Options | | | | | | | | | | | | |
|------------------------|-------|-------|-------|-------|-------|-------|-------|-------|-------|-------|-------|-------|
| Option Code "xx" | 08 | 09 | 10 | 11 | 12 | 15 | 18 | 25 | 27 | 28 | 30 | 33 |
| Voltage | 0.8 V | 0.9 V | 1.0 V | 1.1 V | 1.2 V | 1.5 V | 1.8 V | 2.5 V | 2.7 V | 2.8 V | 3.0 V | 3.3 V |

Marking Information

| Marking | Package | Definition |
|---------------|----------|---|
| AABDNN | SOT23-5 | AA: Product code B: Version D: Day code NN: Serial No |
| A W | DFN1x1-4 | A: Product code W: Week code |
| AABC | DFN2x2-6 | AA: Product code B: Version C: Week code |

PIN CONFIGURATION

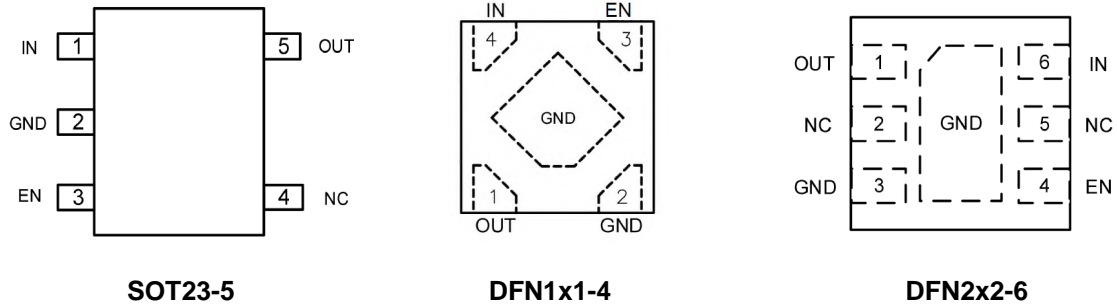

Pin Assignment (Top View)

FUNCTIONAL PIN DESCRIPTION

| TERMINAL NAME | I/O ⁽¹⁾ | DESCRIPTION |
|---------------|--------------------|--|
| OUT | O/P | Output voltage pin. |
| EN | I | Enable pin. This pin has a 100 nA pull-down current source. Connect to logic "High" for normal operation. |
| GND | G | Power supply ground. |
| IN | I/P | Input voltage pin. |
| NC | G | No connection. |

(1) I – Input; O – Output; P – Power; G – Ground

ABSOLUTE MAXIMUM RATINGS

Over operating free-air temperature range (unless otherwise noted) ⁽¹⁾

| PARAMETER | | MIN | MAX | Unit |
|---|--------------------------------------|------|-----------------|------|
| Voltage range at terminals ⁽²⁾ | V _{IN} | -0.3 | 6.5 | V |
| | V _{OUT} , EN | -0.3 | V _{IN} | V |
| I _{OUT} | Output Current | | 300 | mA |
| T _L | Lead temperature range | | 260 | °C |
| T _J ⁽²⁾ | Operating junction temperature range | -40 | 150 | °C |
| T _{STG} | Storage temperature range | -65 | 150 | °C |

- (1) Stresses beyond those listed under **absolute maximum ratings** may cause permanent damage to the device. These are stress ratings only, and functional operation of the device at these or any other conditions beyond those indicated under **recommended operating conditions** is not implied. Exposure to absolute-maximum-rated conditions for extended periods may affect device reliability.
- (2) Operating at junction temperatures greater than 125°C, although possible, degrades the lifetime of the device.

HANDLING RATINGS

| PARAMETER | DEFINITION | MIN | MAX | UNIT |
|--------------------|---|------|-----|------|
| ESD ⁽¹⁾ | Human Body Model (HBM) ESD stress voltage ⁽²⁾ | -2 | 2 | kV |
| | Charged Device Model (CDM) ESD stress voltage ⁽³⁾ , all pins | -500 | 500 | V |

- (1) Electrostatic discharge (ESD) to measure device sensitivity and immunity to damage caused by assembly line electrostatic discharges into the device.
- (2) Level listed above is the passing level per ANSI, ESDA, and JEDEC JS-001. JEDEC document JEP155 states that 500-V HBM allows safe manufacturing with a standard ESD control process.
- (3) Level listed above is the passing level per EIA-JEDEC JESD22-C101. JEDEC document JEP157 states that 250-V CDM allows safe manufacturing with a standard ESD control process.

RECOMMENDED OPERATING CONDITIONS

| PARAMETER | | MIN | TYP | MAX | UNIT |
|------------------|--|-----|-----|-----|------|
| V _{IN} | Input voltage range | 1.6 | | 5.5 | V |
| T _J | Operating junction temperature | -40 | | 125 | °C |
| R _{θJA} | Junction-to-ambient thermal resistance, SOT23-5 | | 235 | | °C/W |
| | Junction-to-ambient thermal resistance, DFN1x1-4 | | 250 | | °C/W |
| | Junction-to-ambient thermal resistance, DFN2x2-6 | | 80 | | °C/W |

ELECTRICAL CHARACTERISTICS

$V_{IN} = V_{OUT} + 1\text{ V}$, $I_{OUT} = 1\text{ mA}$, $C_{IN} = C_{OUT} = 1.0\mu\text{F}$, $T_A = -40^\circ\text{C}$ to 125°C . Typical value is tested at $T_J = +25^\circ\text{C}$, unless otherwise noted.

| Symbol | Parameter | Condition | Min | Typ | Max | Unit | |
|---|-----------------------------|--|------------------------------|------|-----|---------------|----|
| V_{IN} | Input voltage | | 1.6 | | 5.5 | V | |
| $V_{OUT}^{(1)}$ | Output voltage | | 0.8 | | 3.3 | V | |
| | Output accuracy | $V_{OUT} < 2\text{ V}$, $T_A = 25^\circ\text{C}$ | -20 | | 20 | mV | |
| $V_{OUT} \geq 2\text{ V}$, $T_A = 25^\circ\text{C}$ | | -1 | | 1 | % | | |
| I_{LIM} | Output current limit | $V_{OUT} = 90\% V_{OUT(NOM)}$ | | 480 | | mA | |
| V_{DO} | Dropout voltage | $V_{OUT} = 0.95 \times V_{OUT(NOM)}$, $I_{OUT} = 300\text{ mA}$ | $V_{OUT(NOM)} = 0.8\text{V}$ | | 950 | | mV |
| | | | $V_{OUT(NOM)} = 1.2\text{V}$ | | 650 | | |
| | | | $V_{OUT(NOM)} = 1.8\text{V}$ | | 280 | | |
| | | | $V_{OUT(NOM)} = 2.5\text{V}$ | | 200 | | |
| | | | $V_{OUT(NOM)} = 2.8\text{V}$ | | 170 | | |
| | | | $V_{OUT(NOM)} = 3.0\text{V}$ | | 160 | | |
| | | | $V_{OUT(NOM)} = 3.3\text{V}$ | | 150 | | |
| $\frac{\Delta V_{OUT}}{\Delta V_{IN} \times V_{OUT}}$ | Line regulation | $(V_{OUT(NOM)} + 1.0\text{ V}) \leq V_{IN} \leq 5.5\text{ V}$ | | 0.02 | | %/V | |
| ΔV_{OUT} | Load regulation | $I_{OUT} = 0\text{ mA}$ to 350 mA , $T_A = +25^\circ\text{C}$ | | | 40 | mV | |
| I_Q | Quiescent current | No load | | 25 | | μA | |
| I_{SC} | Short circuit current | $V_{OUT} = 0\text{ V}$ | | 220 | | mA | |
| I_{SHDN} | Shut-down current | $V_{EN} = 0\text{ V}$, $V_{IN} = 5.5\text{ V}$ | | 0.1 | | μA | |
| PSRR | Power supply rejection rate | $I_{OUT} = 20\text{ mA}$ | $f = 100\text{ Hz}$ | | 80 | | dB |
| | | | $f = 1\text{ kHz}$ | | 75 | | dB |
| | | | $f = 10\text{ kHz}$ | | 70 | | dB |
| | | | $f = 100\text{ kHz}$ | | 60 | | dB |
| | | | $f = 1\text{ MHz}$ | | 45 | | dB |
| V_{IH} | EN pin threshold voltage | EN logic high voltage | 1 | | | V | |
| V_{IL} | | EN logic low voltage | | | 0.4 | V | |

| | | | | | | |
|-------------|-----------------------------|--|--------------------------|-----|--|---------------------|
| I_{EN} | EN pull-down current | $V_{EN} = 5.5 \text{ V}$ | | 0.1 | | μA |
| e_n | Output voltage noise | $f = 10 \text{ Hz to } 100 \text{ kHz}, V_{OUT} = 1.8 \text{ V}, I_{OUT} = 1 \text{ mA}$ | | 50 | | μV_{RMS} |
| T_{SD} | Thermal shutdown threshold | Shutdown, temperature increasing | $I_{OUT} = 1 \text{ mA}$ | 175 | | $^{\circ}\text{C}$ |
| | | Reset, temperature decreasing | | 145 | | |
| R_{DISCH} | Output discharge resistance | $V_{EN} \leq 0.2 \text{ V}, V_{IN} = 5 \text{ V}$ (only PJ20030A) | | 100 | | Ω |
| t_{ON} | Turn-on time | From assertion of V_{EN} to $V_{OUT} = 90\% V_{OUT(NOM)}$ | | 120 | | μS |

Note:

- (1) It is not recommended to use at 125°C without load.
- (2) Specifications subject to change without notice.

TYPICAL PERFORMANCE CHARACTERISTIC

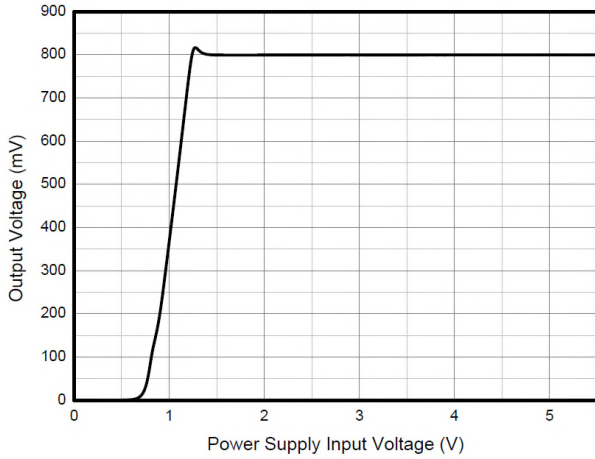

$C_{IN} = C_{OUT} = 1 \mu F, I_{OUT} = 1 \text{ mA}, V_{OUT} = 0.8 \text{ V}$
Figure-2. Output voltage vs. Input voltage

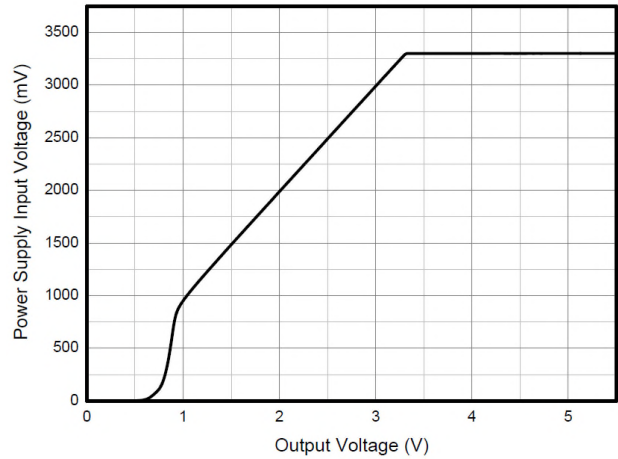

$C_{IN} = C_{OUT} = 1 \mu F, I_{OUT} = 1 \text{ mA}, V_{OUT} = 3.3 \text{ V}$
Figure-3. Input voltage vs. Output voltage

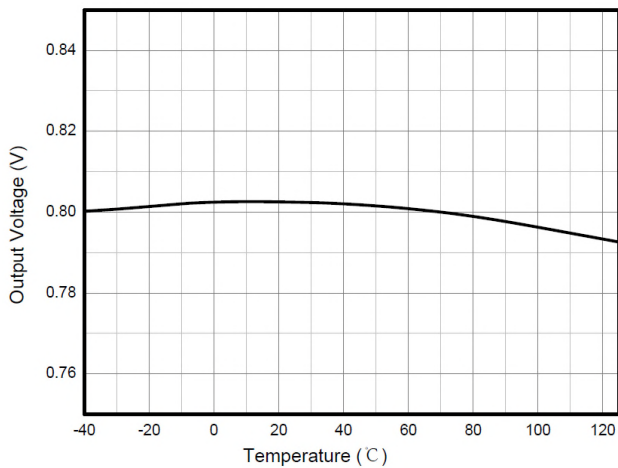

$V_{OUT} = 0.8 \text{ V}, C_{IN} = C_{OUT} = 1 \mu F, I_{OUT} = 1 \text{ mA}$
Figure-4. Output voltage vs. Temperature

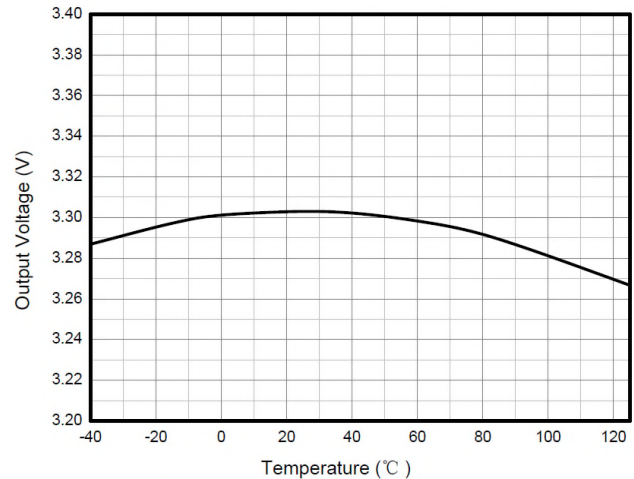

$V_{OUT} = 3.3 \text{ V}, C_{IN} = C_{OUT} = 1 \mu F, I_{OUT} = 1 \text{ mA}$
Figure-5. Output voltage vs. Temperature

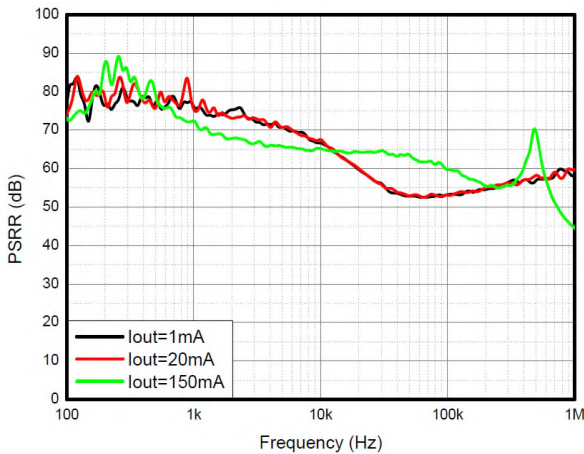

$C_{OUT} = 1 \mu F, V_{IN} = (2.5 \text{ V} + 200 \text{ mVpp}), V_{OUT} = 0.8 \text{ V}$
Figure-6. PSRR vs. Frequency

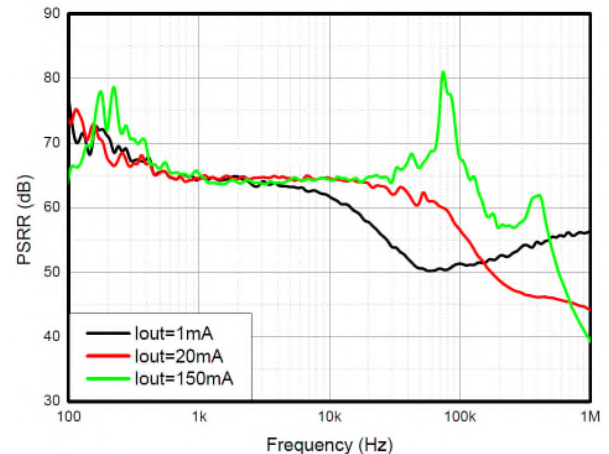

$C_{OUT} = 1 \mu F, V_{IN} = (4.3 \text{ V} + 200 \text{ mVpp}), V_{OUT} = 3.3 \text{ V}$
Figure-7. PSRR vs. Frequency

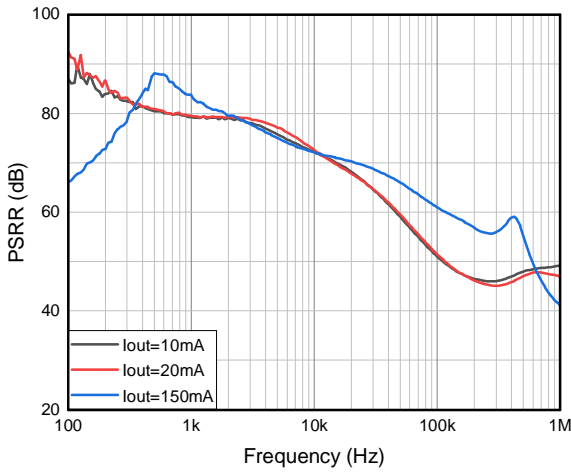

$C_{OUT} = 1 \mu F, V_{IN} = (3 V + 500 mV_{PP}), V_{OUT} = 1.1 V$
Figure-8. PSRR vs. Frequency

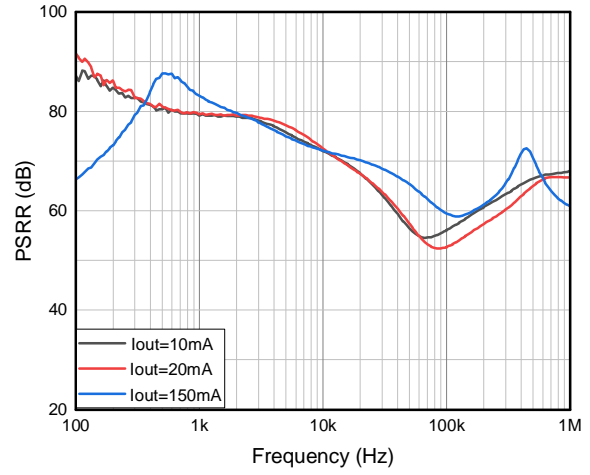

$C_{OUT}=10 \mu F, V_{IN} = (3 V + 500 mV_{PP}), V_{OUT} = 1.1 V$
Figure-9. PSRR vs. Frequency

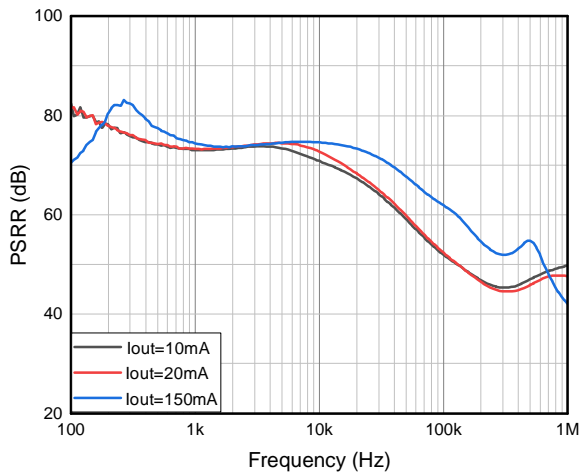

$C_{OUT} = 1 \mu F, V_{IN} = (2.8 V + 500 mV_{PP}), V_{OUT} = 1.8 V$
Figure-10. PSRR vs. Frequency

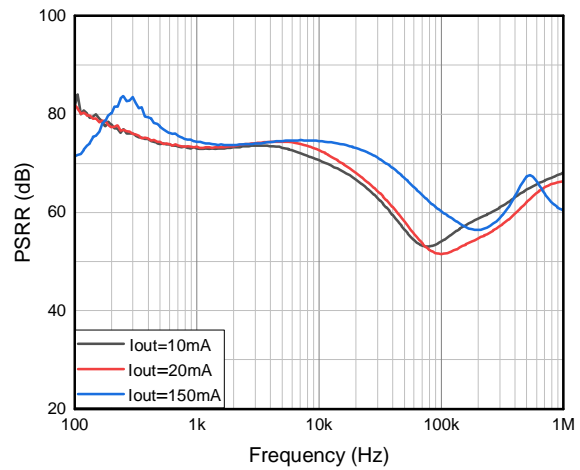

$C_{OUT} = 10 \mu F, V_{IN} = (2.8 V + 500 mV_{PP}), V_{OUT} = 1.8 V$
Figure-11. PSRR vs. Frequency

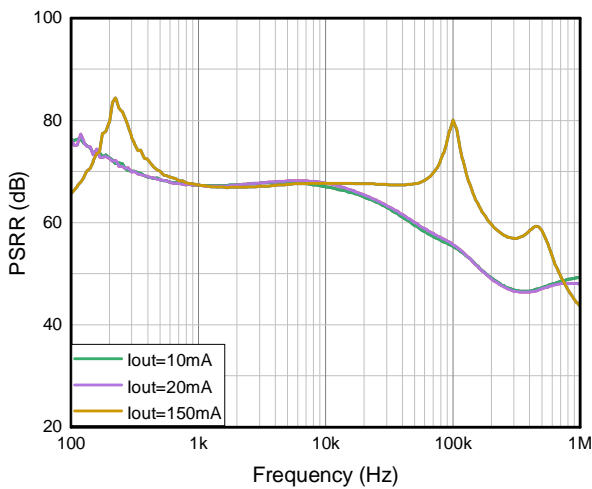

$C_{OUT} = 1 \mu F, V_{IN} = (3.8 V + 500 mV_{PP}), V_{OUT} = 2.8 V$
Figure-12. PSRR vs. Frequency

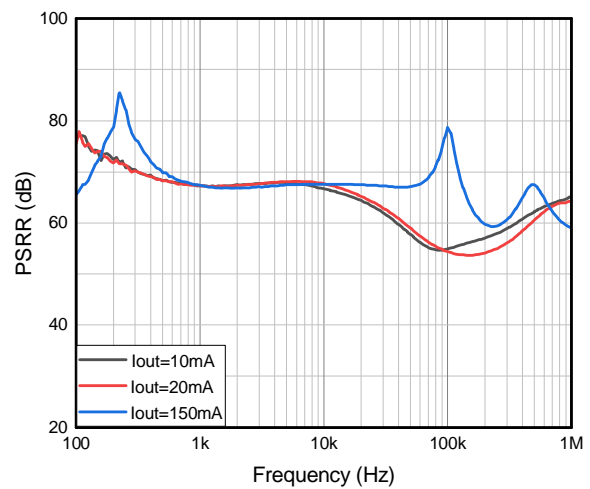

$C_{OUT} = 10 \mu F, V_{IN} = (3.8 V + 500 mV_{PP}), V_{OUT} = 2.8 V$
Figure-13. PSRR vs. Frequency

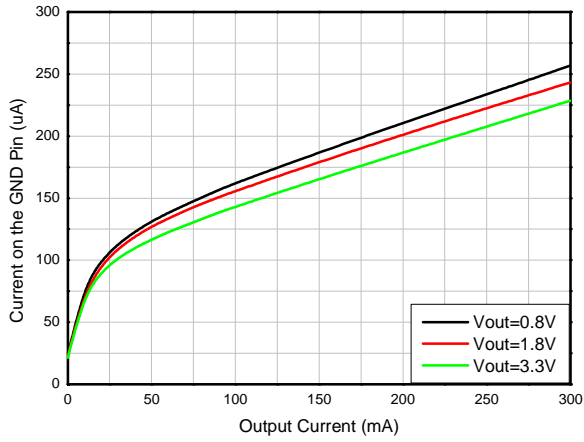

$C_{OUT} = 1 \mu F$, $V_{IN} = (V_{OUT} + 1 V)$ or 2.5 V whichever is higher
Figure-14. Current on the GND pin vs. Output current

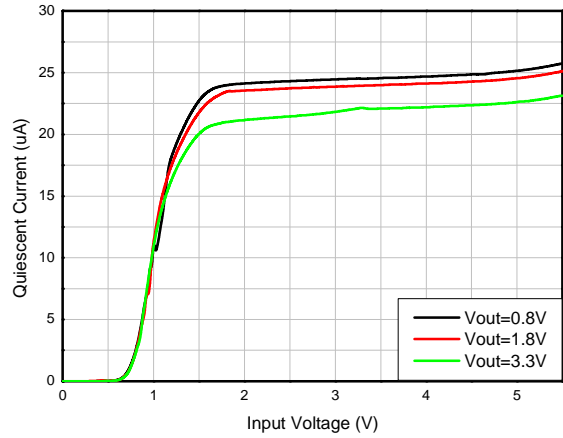

$C_{OUT} = 1 \mu F$, $I_{OUT} = 0 mA$
Figure-15. Quiescent current vs. Input voltage

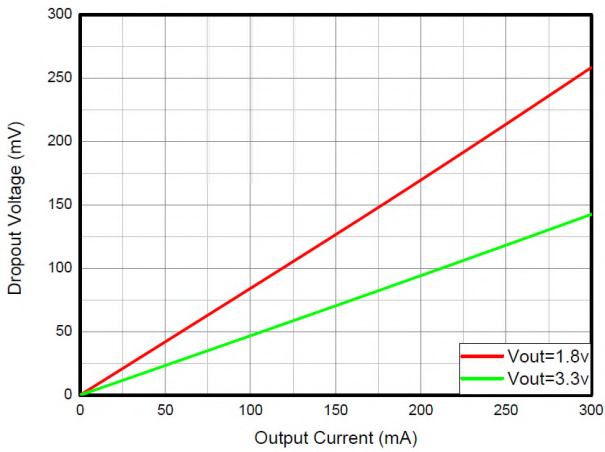
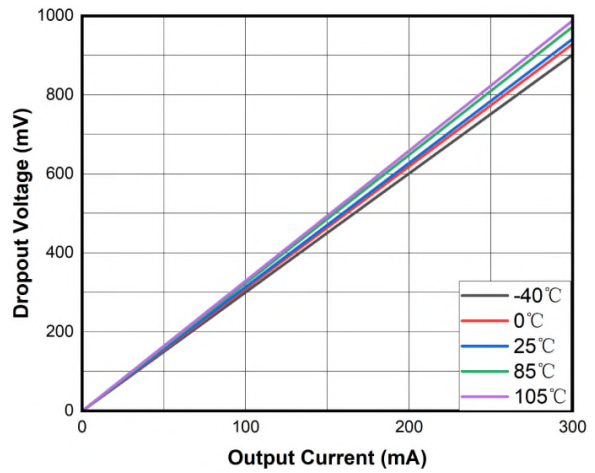
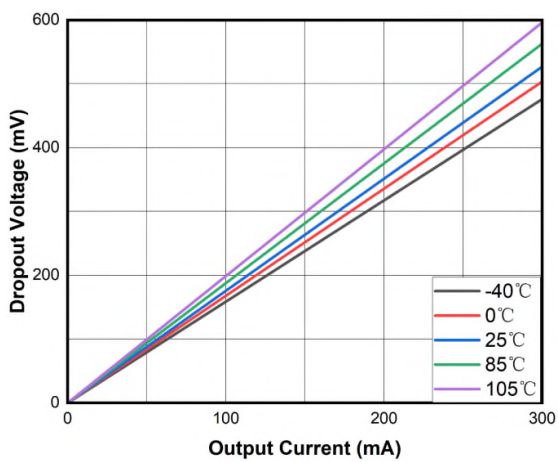

Figure-16. Dropout voltage vs. Output current



$V_{OUT} = 0.8 V$, $I_L = 300 mA$, $V_{EN} = 1 V$
Figure-17. Dropout voltage vs. Output current



$V_{OUT} = 1.2 V$, $I_L = 300 mA$, $V_{EN} = 1 V$
Figure-18. Dropout voltage vs. Output current

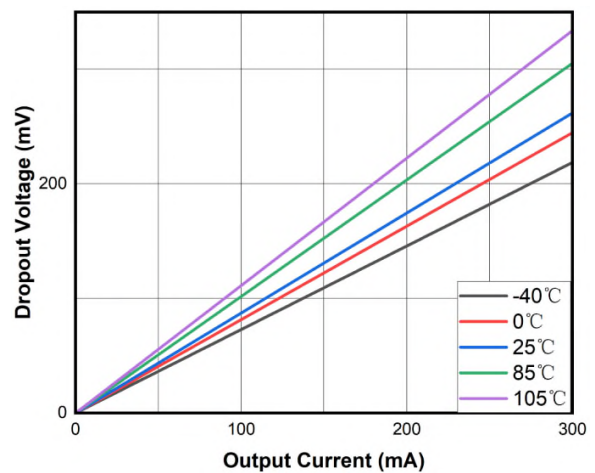

$V_{OUT} = 1.8 V$, $I_L = 300 mA$, $V_{EN} = 1 V$
Figure-19. Dropout voltage vs. Output current

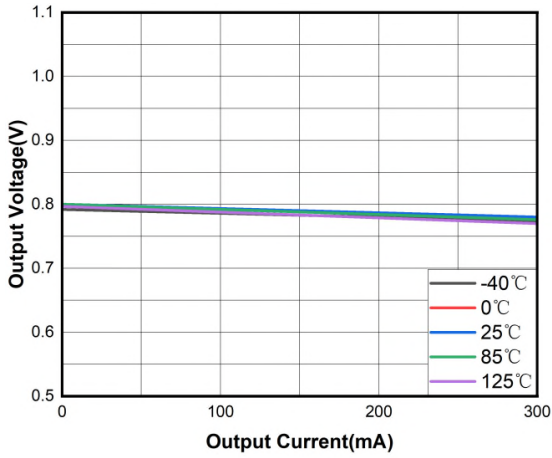

$V_{IN} = 2.5\text{ V}$, $V_{OUT} = 0.8\text{ V}$, $V_{EN} = 1\text{ V}$

Figure-20. Load regulation vs. Output current

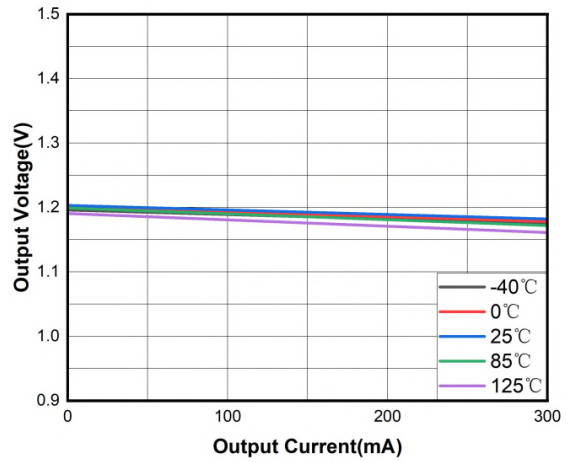

$V_{IN} = 2.5\text{ V}$, $V_{OUT} = 1.2\text{ V}$, $V_{EN} = 1\text{ V}$

Figure-21. Load regulation vs. Output current

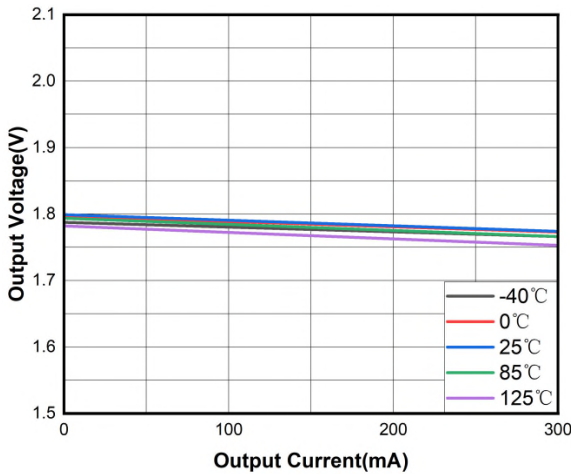

$V_{IN} = 2.8\text{ V}$, $V_{OUT} = 1.8\text{ V}$, $V_{EN} = 1\text{ V}$

Figure-22. Load regulation vs. Output current

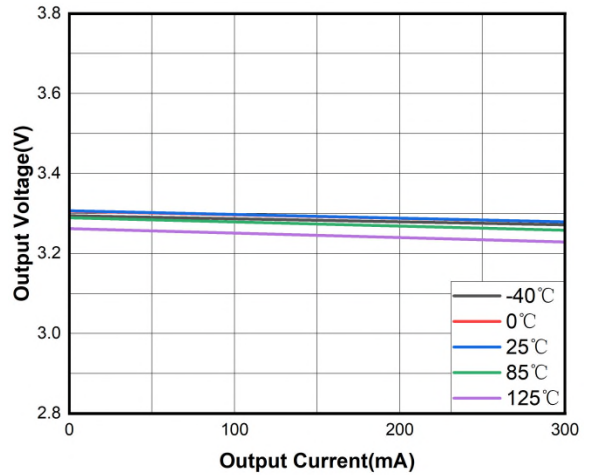

$V_{IN} = 4.3\text{ V}$, $V_{OUT} = 3.3\text{ V}$, $V_{EN} = 1\text{ V}$

Figure-23. Load regulation vs. Output current

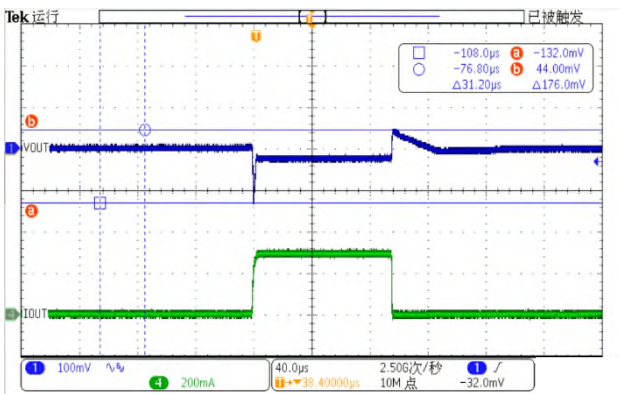

$V_{IN} = 2.5\text{ V}$, $V_{OUT} = 0.8\text{ V}$, $C_{IN} = C_{OUT} = 1\text{ }\mu\text{F}$

Figure-24. Load transient response at load step from 1 mA to 300 mA, $V_{OUT} = 0.8\text{ V}$

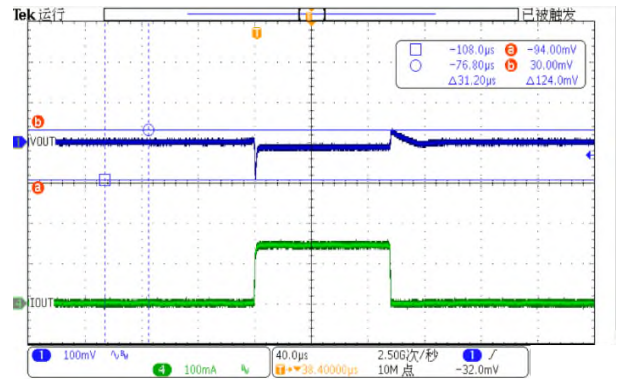

$V_{IN} = 2.5\text{ V}$, $V_{OUT} = 0.8\text{ V}$, $C_{IN} = C_{OUT} = 1\text{ }\mu\text{F}$

Figure-25. Load transient response at load step from 1 mA to 150 mA, $V_{OUT} = 0.8\text{ V}$

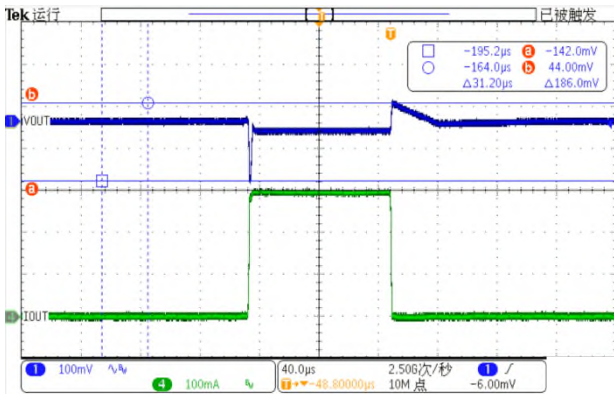

$V_{IN} = 4.3 \text{ V}$, $V_{OUT} = 3.3 \text{ V}$, $C_{IN} = C_{OUT} = 1 \mu\text{F}$
Figure-26. Load transient response at load step from 1 mA to 300 mA, $V_{OUT} = 3.3 \text{ V}$

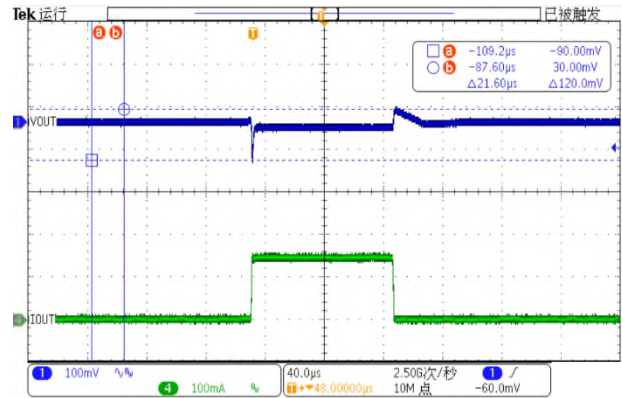

$V_{IN} = 4.3 \text{ V}$, $V_{OUT} = 3.3 \text{ V}$, $C_{IN} = C_{OUT} = 1 \mu\text{F}$
Figure-27. Load transient response at load step from 1 mA to 150 mA, $V_{OUT} = 3.3 \text{ V}$

FUNCTIONAL BLOCK DIAGRAM

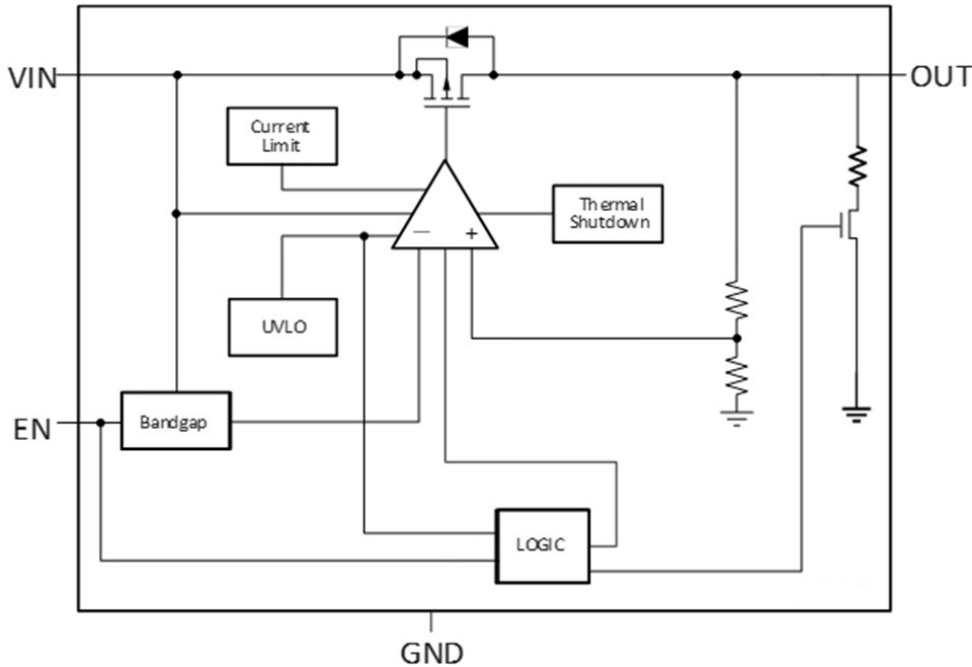

Overview

The PJ20030 series of LDO linear regulators is low quiescent current devices with excellent line and load transient performance. These LDOs are designed for power-sensitive applications. A precision bandgap and error amplifier provide overall $\pm 1\%$ accuracy. Low output noise, very high PSRR, and low dropout voltage make this series of devices ideal for most battery-operated handheld equipment. All device versions have integrated thermal shutdown, and current limit.

Internal current limit

The PJ20030 internal current limit helps to protect the regulator during fault conditions. During the current limit, the output sources a fixed amount of current that is largely independent of the output voltage. In such a case, the output voltage is not regulated and $V_{OUT} = I_{CL} \times R_{LOAD}$. The PMOS pass transistor dissipates $(V_{IN} - V_{OUT}) \times I_{CL}$ until the thermal shutdown is triggered and the device turns off. As the device cools down, it is turned on by the internal thermal shutdown circuit. If the fault condition continues, the device cycles between the current limit and thermal shutdown.

Shut down

The enable pin (EN) is active high. The device is enabled when the voltage at the EN pin goes above 1V. The device is turned off when the EN pin is held at less than 0.4V. When shutdown capability is not required, EN can be connected to the IN pin.

Dropout voltage

The PJ20030 uses a PMOS pass transistor to achieve low dropout. When $(V_{IN} - V_{OUT})$ is less than the dropout voltage (V_{DO}), the PMOS pass device is in the linear region of operation and the input-to-output resistance is the $R_{DS(on)}$ of the PMOS pass element. V_{DO} scales approximately with the output current because the PMOS device behaves as a resistor in dropout.

PACKAGE DIMENSION – SOT23-5

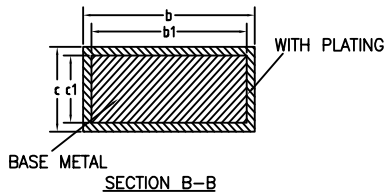
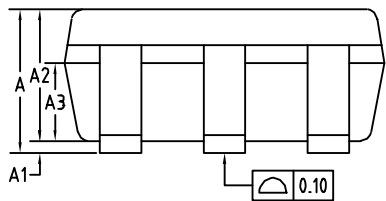
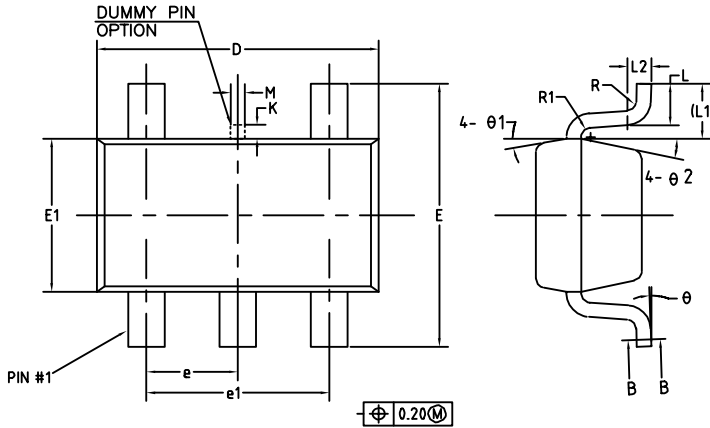

| Common Dimensions (Units of measure = Millimeter) | | | |
|--|-------|----------|-------|
| Symbol | Min | Typ | Max |
| A | - | - | 1.25 |
| A1 | 0 | - | 0.15 |
| A2 | 1.00 | 1.10 | 1.20 |
| A3 | 0.60 | 0.65 | 0.70 |
| b | 0.36 | - | 0.45 |
| b1 | 0.35 | 0.38 | 0.41 |
| c | 0.14 | - | 0.20 |
| c1 | 0.14 | 0.15 | 0.16 |
| D | 2.826 | 2.926 | 3.026 |
| E | 2.60 | 2.80 | 3.00 |
| E1 | 1.526 | 1.626 | 1.726 |
| e | 0.90 | 0.95 | 1.00 |
| e 1 | 1.80 | 1.90 | 2.00 |
| K | 0 | - | 0.25 |
| L | 0.30 | 0.40 | 0.60 |
| L1 | | 0.59 REF | |
| L2 | | 0.25 BSC | |
| M | 0.10 | 0.15 | 0.25 |
| R | 0.05 | - | 0.20 |
| R1 | 0.05 | - | 0.20 |
| θ | 0° | - | 8° |
| θ1 | 8° | 10° | 12° |
| θ2 | 10° | 12° | 14° |

PACKAGE DIMENSION – DFN1x1-4

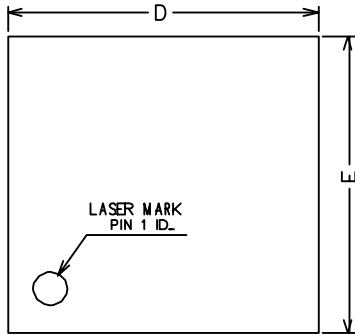

TOP VIEW

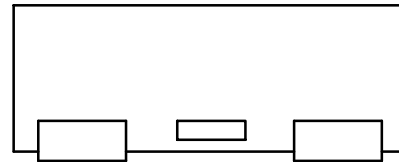

SIDE VIEW

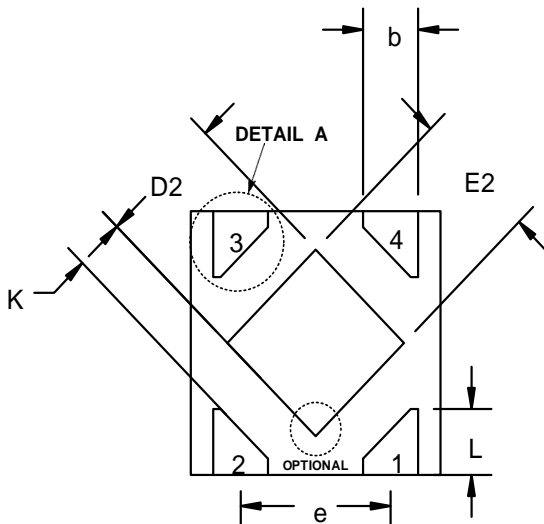

BOTTOM VIEW

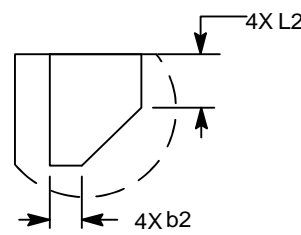

DETAIL A

Two options:

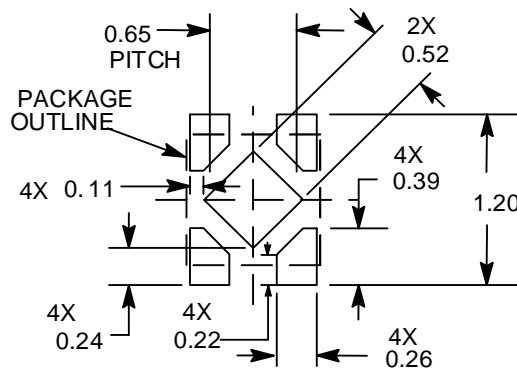
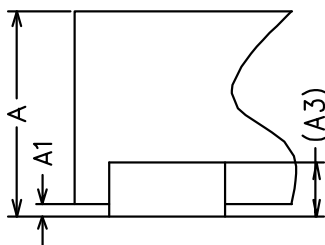
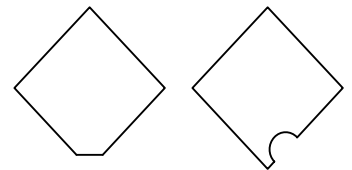

RECOMMENDED LAND PATTERN (Unit: mm)

PACKAGE DIMENSION – DFN1x1-4

| Common Dimensions (Units of measure = Millimeter) | | | |
|--|------------|------------|------------|
| Symbol | Min | Nom | Max |
| A | 0.34 | 0.37 | 0.40 |
| A1 | 0 | 0.02 | 0.05 |
| A3 | 0.10 REF | | |
| b | 0.17 | 0.22 | 0.27 |
| D | 0.95 | 1.00 | 1.05 |
| E | 0.95 | 1.00 | 1.05 |
| D2 | 0.43 | 0.48 | 0.53 |
| E2 | 0.43 | 0.48 | 0.53 |
| L | 0.20 | 0.25 | 0.30 |
| e | 0.60 | 0.65 | 0.70 |
| K | 0.15 | - | - |
| L2 | 0.07 | 0.12 | 0.17 |
| b2 | 0.02 | - | 0.12 |

PACKAGE DIMENSION – DFN2x2-6

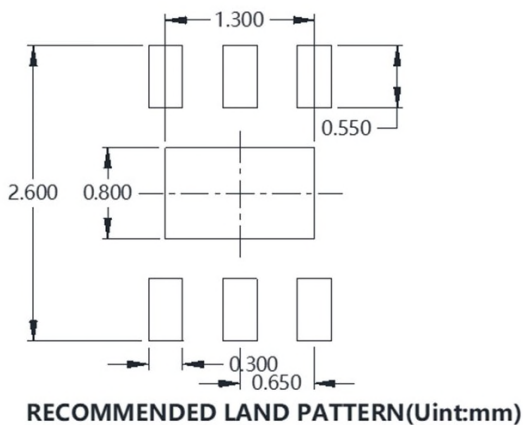
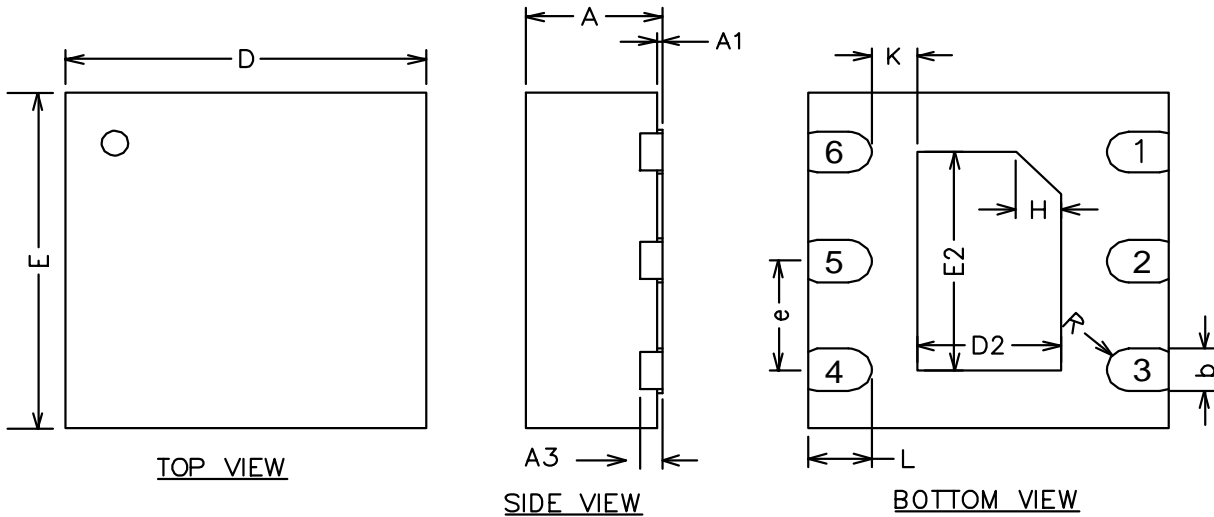

| Common Dimensions (Units of measure = Millimeter) | | | |
|--|----------|------|------|
| Symbol | Min | Nom | Max |
| A | 0.70 | 0.75 | 0.80 |
| A1 | 0.00 | 0.02 | 0.05 |
| A3 | 0.20 REF | | |
| b | 0.20 | 0.25 | 0.30 |
| D | 1.90 | 2.00 | 2.10 |
| E | 1.90 | 2.00 | 2.10 |
| D2 | 0.70 | 0.80 | 0.90 |
| E2 | 1.20 | 1.30 | 1.40 |
| e | 0.55 | 0.65 | 0.75 |
| H | 0.25 REF | | |
| K | 0.20 | - | - |
| L | 0.30 | 0.35 | 0.40 |
| R | 0.11 | - | - |

Disclaimer

- Reproducing and modifying information of the document is prohibited without permission from Panjit International Inc..
- Panjit International Inc. reserves the rights to make changes of the content herein the document anytime without notification. Please refer to our website for the latest document.
- Panjit International Inc. disclaims any and all liability arising out of the application or use of any product including damages incidentally and consequentially occurred.
- Panjit International Inc. does not assume any and all implied warranties, including warranties of fitness for particular purpose, non-infringement and merchantability.
- Applications shown on the herein document are examples of standard use and operation. Customers are responsible in comprehending the suitable use in particular applications. Panjit International Inc. makes no representation or warranty that such applications will be suitable for the specified use without further testing or modification.
- The products shown herein are not designed and authorized for equipments requiring high level of reliability or relating to human life and for any applications concerning life-saving or life-sustaining, such as medical instruments, transportation equipment, aerospace machinery et cetera. Customers using or selling these products for use in such applications do so at their own risk and agree to fully indemnify Panjit International Inc. for any damages resulting from such improper use or sale.
- Since Panjit uses lot number as the tracking base, please provide the lot number for tracking when complaining